



# STORAGE SYSTEM

—  
FOR CNC TOOLS

















































# TABLE OF CONTENTS

<b>TABLE OF CONTENTS</b>	<b>2</b>	<b>WORKSTATION SYSTEM</b>	<b>15</b>
<b>Legend</b>	<b>3</b>	Multi-Purpose Workstation . . . . .	15
<b>CNC TOOL STORAGE SYSTEM</b>	<b>4</b>	Maintenance Workstation with CNC Tool Racks . . . . .	16
<b>TOOL RACKS</b>	<b>6</b>	Temporary Storage Workstation. . . . .	16
Shelving . . . . .	6	Mobile Workbench . . . . .	16
WM Uprights. . . . .	6		
R Cabinets . . . . .	6	<b>5S STORAGE</b>	<b>17</b>
TekZone Hutch. . . . .	6	Wall-Mounted Panel System . . . . .	17
Mini-Racking . . . . .	6	Drawer Accessories . . . . .	17
<b>MOBILE FREESTANDING STATIONS FOR CNC TOOLS</b>	<b>8</b>	<b>MULTITEK CART</b>	<b>19</b>
Mobile Freestanding Station for CNC Tools - 36"H . . . . .	8	Material Handling Cart . . . . .	19
Mobile Freestanding Station for CNC Tools - 54"H . . . . .	8	Maintenance Cart . . . . .	19
<b>STATIONARY STORAGE FOR CNC TOOLS</b>	<b>9</b>	Technicians Cart for Frequent Trips . . . . .	19
Freestanding Station for CNC Tools - 54"H . . . . .	9	Shelf Accessories . . . . .	19
R Cabinet with CNC Tool Drawers. . . . .	9	Drawer Accessories . . . . .	19
Shelving with CNC Tool Drawers . . . . .	10		
Shelving for CNC Tools . . . . .	10		
<b>SPIDER® SHELVING SYSTEM</b>	<b>11</b>		
Open Shelving . . . . .	11		
Closed Shelving . . . . .	11		
<b>Drawers in Shelving</b>	<b>12</b>		
Shelving with 4 Drawers . . . . .	12		
Shelving with 7 Drawers / Roll-Out Shelf . . . . .	12		
Shelving with 8 Drawers . . . . .	12		
<b>Drawer Partitioning</b>	<b>12</b>		
<b>MINI-RACKING FOR CNC TOOLS</b>	<b>13</b>		
<b>STORAGE CABINETS, STATIONARY AND MOBILE</b>	<b>14</b>		
High-Density Storage Cabinet . . . . .	14		
Mobile Repair / Preparation Cabinet for CNC Tools . . . . .	14		
Multi-Drawer Mobile Cabinet . . . . .	14		

THIS BROCHURE FEATURES  
THE MOST POPULAR MODELS.  
CONTACT US TO FULLY EXPLORE  
A WORLD OF POSSIBILITIES

## LEGEND

You will find various icons throughout this document. Here are their meanings:

 Width	 Closed Shelving	 Laminated Wood Surfaces	 Maximum Tool Quantity
 Depth	 Starter	 Stainless Steel Surfaces	 No Doors
 Height	 Add-On	 Painted Steel Surfaces	 Solid Doors
 Capacity	 SR Perforated Post	 Painted Steel Surfaces With Rubber Mat	 Polycarbonate Doors
 Drawers	 SH Smooth Finish Post	 Plastic Laminated Surfaces	 MultiTek Shelf
 Drawer Compartments	 Welded Upright	 True One-Drawer-at-a-Time System	 MultiTek Shelf Quantity
 Drawer Bank	 Shelves	 Integrated Lock-In Mechanism	 MultiTek Roll-Out Shelf
 Multi-Drawer Banks	 Adjustable Shelves	 Econo Lock-In Mechanism	
 Upper Bank	 Shelf Dividers	 Central Lock	
 Left Bank	 Platform Levels	 L3 Lock	
 Right Bank	 Steel Decking	 15A Electrical Outlets	
 Roll-Out Shelves	 Wire Mesh Decking	 Quantity	
 Open Shelving	 PVC Decking Levels	 No NC Tool Racks	
 Starter	 Blank PVC Decking	 NC Tool Rack Quantity	
 Add-On	 Casters	 Blank NC Tool Rack	

# CNC TOOL STORAGE SYSTEM

Rousseau's CNC tool storage system has been designed to provide maximum protection for your tools while offering optimal storage.

With its original two-level design, the tool rack offers improved support and excellent stability by preventing tools from falling out, even in an inclined position. The tool rack surface is made of sturdy PVC and protects tools against blows, corrosion and spattering molten metal, while allowing for coolant drainage and limiting contact surfaces with the tool.

The tool rack has perforations for Taper, Straight, Sandvik Capto, HSK, KM and VDI tools. The tool rack is also available without perforations.





# CNC TOOL RACKS

The CNC tool rack seamlessly integrates into all Rousseau product lines: Spider® Shelving, R Cabinets, WM Bench Frames and TekZone Hutches. Lightweight yet heavy duty, the racks have ergonomic handles to facilitate tool handling. Its distinctive advantage lies in the rack's resistant PVC extruded design. It can withstand blows and corrosion while allowing fluids to drain away, which prolongs the life of your tools. In addition, the racks feature a tool labeling area for quick and easy identification.

With Rousseau NC tool racks, you reduce your purchase and refurbishing costs.

## Main benefits:

- Compatible with the most popular tools on the market
- Provides secure storage for your tools
- Integrates into all Rousseau product lines

## SHELVING

Compatible with the following Spider® Shelving: 30"W x 24"D, 36"W x 18"D and 36"W x 24"D with NC51 adapters

## WM UPRIGHTS

Installs in 28"W and 34"W WM11, WMA and WM35 frames with NC50 adapters

## R CABINET

Compatible with the following RF31/RF32/RF33/RF34/RF35/RF36 modular drawers: 30"W x 21"D, 36"W x 18"D, 30"W x 24"D, 36"W x 24"D, 30"W x 27"D with NC54 adapters

## TEKZONE HUTCH

Attaches to TekZone Hutch rear utility panels at the desired height

## MINI-RACKING

PVC decks for Mini-Racking for 48"W, 60"W and 72"W  
Mini-Racking levels available: NC33 and NC34

Perforated model numbers must be completed with the tool code

SHELVING - WM UPRIGHTS AND FRAMES - CABINETS				
DIMENSIONS	30"W TOOL RACK		36"W TOOL RACK	
C/C DIMENSIONS	28" C/C		34" C/C	
ACTUAL DIMENSIONS	25 1/4"W x 5"D x 7 1/4"H		31 1/4"W x 5"D x 7 1/4"H	
TOOL TYPE	PRODUCT NO.	NO. OF HOLES	PRODUCT NO.	NO. OF HOLES
Blank rack	NC10-3000	–	NC10-3600	–
Taper 30	NC12-3001	10	NC12-3601	12
Taper 40	NC12-3003	7	NC12-3603	9
Taper 45	NC12-3004	6	NC12-3604	7
Taper 50	NC12-3005	5	NC12-3605	6
3/4" Straight	NC12-3010	20	NC12-3610	26
1" Straight	NC12-3011	20	NC12-3611	26
1 1/4" Straight	NC12-3013	20	NC12-3613	26
1 1/2" Straight	NC12-3015	8	NC12-3615	10
1 3/4" Straight	NC12-3016	8	NC12-3616	10
2" Straight	NC12-3018	6	NC12-3618	7
2 1/4" Straight	NC12-3019	6	NC12-3619	7
2 1/2" Straight	NC12-3021	6	NC12-3621	7
C3 Sandvik Capto	NC12-3030	22	NC12-3630	26
C4 Sandvik Capto	NC12-3031	22	NC12-3631	26
C5 Sandvik Capto	NC12-3032	10	NC12-3632	12
C6 Sandvik Capto	NC12-3033	7	NC12-3633	9
C8 Sandvik Capto	NC12-3034	6	NC12-3634	7
HSK 25 (A-C-E)	NC12-3040	22	NC12-3640	26
HSK 32 (A-C-E)	NC12-3041	22	NC12-3641	26
HSK 40 (A-C-E)	NC12-3042	22	NC12-3642	26
HSK 50 (A-C-E)	NC12-3043	10	NC12-3643	12
HSK 63 (A-C-E)	NC12-3044	7	NC12-3644	9
HSK 80 (A-C-E)	NC12-3045	5	NC12-3645	6
HSK 100 (A-C-E)	NC12-3046	4	NC12-3646	5
32 KM	NC12-3050	22	NC12-3650	26
40 KM	NC12-3051	22	NC12-3651	26
50 KM	NC12-3052	10	NC12-3652	12
63 KM	NC12-3053	7	NC12-3653	9
80 KM	NC12-3054	5	NC12-3654	6
VDI 30 mm	NC12-3060	6	NC12-3660	7
VDI 40 mm	NC12-3061	5	NC12-3661	6
VDI 50 mm	NC12-3062	4	NC12-3662	5



NC12



NC10

NOTE: All our racks are available in a perforated and blank version. The number of tools that a tool rack can hold varies according to tool diameter and the length of extruded surfaces. The number of holes specified in the table indicates the number of perforations per extruded surface.

TEKZONE HUTCH					MINI-RACKING					
DIMENSIONS		23"W TOOL RACK		29"W TOOL RACK		18"D PVC DECK		24"D PVC DECK		TOOL CODE*
ACTUAL DIMENSIONS		23"W×5"D×4"H		29"W×5"D×4"H		18"D PVC DECK		24"D PVC DECK		
TOOL TYPE	PRODUCT NO.	NO. OF HOLES	PRODUCT NO.	NO. OF HOLES	PRODUCT NO.	NO. OF HOLES	PRODUCT NO.	NO. OF HOLES	TOOL CODE*	
Blank rack	NC14-2300	—	NC14-2900	—	NC30-1800	—	NC30-2400	—	00	
Taper 30	NC15-2301	10	NC15-2901	12	NC31-1801	8	NC31-2401	10	01	
Taper 40	NC15-2303	7	NC15-2903	9	NC31-1803	7	NC31-2403	9	03	
Taper 45	NC15-2304	6	NC15-2904	7	NC31-1804	4	NC31-2404	5	04	
Taper 50	NC15-2305	5	NC15-2905	6	NC31-1805	4	NC31-2405	5	05	
¾" Straight	NC15-2310	20	NC15-2910	26	NC31-1810	14	NC31-2410	18	10	
1" Straight	NC15-2311	20	NC15-2911	26	NC31-1811	14	NC31-2411	18	11	
1¼" Straight	NC15-2313	20	NC15-2913	26	NC31-1813	14	NC31-2413	18	13	
1½" Straight	NC15-2315	8	NC15-2915	10	NC31-1815	5	NC31-2415	7	15	
1¾" Straight	NC15-2316	8	NC15-2916	10	NC31-1816	5	NC31-2416	7	16	
2" Straight	NC15-2318	6	NC15-2918	7	NC31-1818	4	NC31-2418	5	18	
2¼" Straight	NC15-2319	6	NC15-2919	7	NC31-1819	4	NC31-2419	5	19	
2½" Straight	NC15-2321	6	NC15-2921	7	NC31-1821	4	NC31-2421	5	21	
C3 Sandvik Capto	NC15-2330	22	NC15-2930	26	NC31-1830	18	NC31-2430	24	30	
C4 Sandvik Capto	NC15-2331	22	NC15-2931	26	NC31-1831	18	NC31-2431	24	31	
C5 Sandvik Capto	NC15-2332	10	NC15-2932	12	NC31-1832	7	NC31-2432	9	32	
C6 Sandvik Capto	NC15-2333	7	NC15-2933	9	NC31-1833	7	NC31-2433	9	33	
C8 Sandvik Capto	NC15-2334	6	NC15-2934	7	NC31-1834	4	NC31-2434	5	34	
HSK 25 (A-C-E)	NC15-2340	22	NC15-2940	26	NC31-1840	18	NC31-2440	24	40	
HSK 32 (A-C-E)	NC15-2341	22	NC15-2941	26	NC31-1841	18	NC31-2441	24	41	
HSK 40 (A-C-E)	NC15-2342	22	NC15-2942	26	NC31-1842	18	NC31-2442	24	42	
HSK 50 (A-C-E)	NC15-2343	10	NC15-2943	12	NC31-1843	8	NC31-2443	10	43	
HSK 63 (A-C-E)	NC15-2344	7	NC15-2944	9	NC31-1844	5	NC31-2444	7	44	
HSK 80 (A-C-E)	NC15-2345	5	NC15-2945	6	NC31-1845	4	NC31-2445	5	45	
HSK 100 (A-C-E)	NC15-2346	4	NC15-2946	5	NC31-1846	3	NC31-2446	4	46	
32 KM	NC15-2350	22	NC15-2950	26	NC31-1850	18	NC31-2450	24	50	
40 KM	NC15-2351	22	NC15-2951	26	NC31-1851	18	NC31-2451	24	51	
50 KM	NC15-2352	10	NC15-2952	12	NC31-1852	8	NC31-2452	10	52	
63 KM	NC15-2353	7	NC15-2953	9	NC31-1853	5	NC31-2453	7	53	
80 KM	NC15-2354	5	NC15-2954	6	NC31-1854	4	NC31-2454	5	54	
VDI 30 mm	NC15-2360	6	NC15-2960	7	NC31-1860	7	NC31-2460	9	60	
VDI 40 mm	NC15-2361	5	NC15-2961	6	NC31-1861	4	NC31-2461	5	61	
VDI 50 mm	NC15-2362	4	NC15-2962	5	NC31-1862	3	NC31-2462	4	62	



NC15

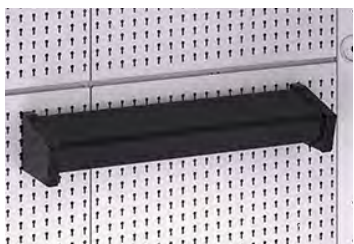

NC14

UPRIGHT ASSEMBLY DEPTHS	TYPE OF SURFACE	UNIT WIDTH		BEAM WIDTH	
		6"	48"	60"	72"
18"	Blank	NC30-1800	NC33-481800	NC33-601800	NC33-721800
	Perforated	NC31-18_*	NC34-4818_*	NC34-6018_*	NC34-7218_*
24"	Blank	NC30-2400	NC33-482400	NC33-602400	NC33-722400
	Perforated	NC31-24_*	NC34-4824_*	NC34-6024_*	NC34-7224_*

NOTE: \* Please add the tool code specified in the Mini-Racking table to complete the perforated surface product number you have selected.

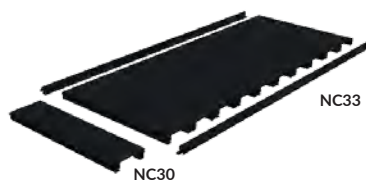

NC33

NC30

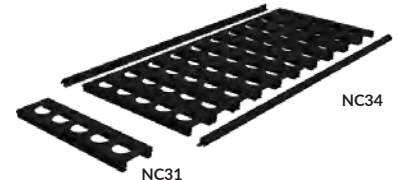

NC34

NC31

# MOBILE FREESTANDING STATIONS FOR CNC TOOLS

Rousseau mobile freestanding stations are designed to optimize your task changes. They make it easy for you to move to a different location while properly protecting your tools.

The mobile stations have ultra-quiet and smooth-rolling polyurethane casters that glide easily even on floors scattered with metal fragments or on greasy surfaces.

The rack's PVC surface protects tools against impacts, corrosion and spattering molten metal. The racks are also tilted 20° for easy handling and access to tools.



**MOBILE FREESTANDING STATION FOR CNC TOOLS - 36" H**

32"	27"	41¼"		
Taper 40	56	NCW0100		
Taper 50	40	NCW0101		
HSK 50	80	NCW0102		
HSK 63	56	NCW0103		
50 KM	80	NCW0104		
63 KM	56	NCW0105		
	-	NCW0106		
	0	NCW0109		

- Includes a shelf with aluminum handle for easier maneuverability
- Ideal for handling CNC tools



**MOBILE FREESTANDING STATION FOR CNC TOOLS - 54" H**

32"	27"	59¼"		
Taper 40	84	NCW0216		
Taper 50	60	NCW0217		
HSK 50	120	NCW0218		
HSK 63	84	NCW0219		
50 KM	120	NCW0220		
63 KM	84	NCW0221		
	-	NCW0222		
	0	NCW0229		

- Includes an aluminum handle for easier maneuverability and a document holder
- For transporting a large number of CNC tools from A to B



Maximum load capacity: 1,200lb. evenly distributed



# STATIONARY STORAGE FOR CNC TOOLS

Whether you want to store specialized metalworking equipment (e.g., drill bits, collets, punches, tool holders) or standard tools (e.g., pliers, files, wrenches, sockets), Rousseau offers a wide range of solutions: freestanding stations, modular cabinets, shelving with drawers, Mini-Racking, and much more. All these options allow you to find the solution that best meets your specific requirements.

Our range of stationary storage provides effective protection against the kind of corrosion and premature wear that results from unsuitable storage. Your tools are precious; let Rousseau help you protect them!



## FREESTANDING STATION FOR CNC TOOLS - 54"H

32"	27"	54"	MAX	
Taper 40	56	NCW0247		
Taper 50	40	NCW0248		
HSK 50	80	NCW0249		
HSK 63	56	NCW0250		
50 KM	80	NCW0251		
63 KM	56	NCW0252		
	-	NCW0258		
	0	NCW0259		

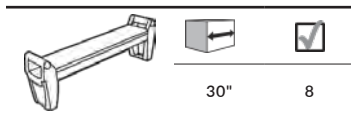

- Includes 2 plastic bin rails, 2 tiltable shelves and 6 partial dividers
- Keeps your tools safe, secure and within easy reach

NOTE: Red plastic bins are not available from Rousseau.



## R CABINET WITH CNC TOOL DRAWERS

30"	7"	3	12
			400lb

30"	27"	60"	MAX			
Taper 40	84	NCM0011		NCM0012		NCM0013
Taper 50	60	NCM0061		NCM0062		NCM0063
HSK 50	120	NCM0111		NCM0112		NCM0113
HSK 63	84	NCM0161		NCM0162		NCM0163
50 KM	120	NCM0211		NCM0212		NCM0213
63 KM	84	NCM0261		NCM0262		NCM0263
	-	NCM0945		NCM0946		NCM0947
	0	NCM0091		NCM0092		NCM0093

36"	7"	3	12	400lb

36"	24"	60"	MAX			
Taper 40	108	NCM0017		NCM0018		NCM0019
Taper 50	72	NCM0067		NCM0068		NCM0069
HSK 50	144	NCM0117		NCM0118		NCM0119
HSK 63	108	NCM0167		NCM0168		NCM0169
50 KM	144	NCM0217		NCM0218		NCM0219
63 KM	108	NCM0267		NCM0268		NCM0269
	-	NCM0949		NCM0950		NCM0951
	0	NCM0097		NCM0098		NCM0099

NOTE: If your tool type is not listed in these tables, see page 6 or contact Customer Service.

# STATIONARY STORAGE FOR CNC TOOLS

## SHELVING WITH CNC TOOL DRAWERS

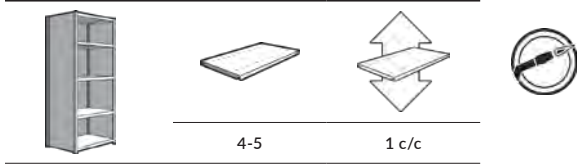

				TAPER 40	TAPER 50	HSK 50	HSK 63	50 KM	63 KM			
30"	24"	75"	4	2	NCS2251	NCS2261	NCS2271	NCS2281	NCS2291	NCS2301	NCS2308	NCS2391
		87"	5	4	NCS2252	NCS2262	NCS2272	NCS2282	NCS2292	NCS2302	NCS2307	NCS2392
					56	40	80	56	80	56	-	0
36"	24"	75"	4	2	NCS2255	NCS2265	NCS2275	NCS2285	NCS2295	NCS2305	NCS2309	NCS2395
		87"	5	4	NCS2256	NCS2266	NCS2276	NCS2286	NCS2296	NCS2306	NCS2310	NCS2396
					72	48	96	72	96	72	-	0

Drawer Height	Tray Height	Tray Width	Tray Depth	Weight
30"	3"	1	-	400lb
	4"	2	-	
	7"	2	8	

- 3 drawers
  - 1 drawer with groove trays, 3"H
  - 1 drawer with tool foam, 4"H
  - 1 drawer with compartments, 4"H
- Provides full and unrestricted access to the drawer contents



Shelving with drawers must be anchored to the floor.

## SHELVING FOR CNC TOOLS

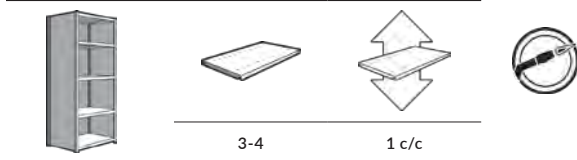

				TAPER 40	TAPER 50	HSK 50	HSK 63	50 KM	63 KM			
36"	18"	75"	3	2	NCS4005	NCS4025	NCS4045	NCS4065	NCS4085	NCS4105	NCS4114	NCS4195
		87"	4	4	NCS4006	NCS4026	NCS4046	NCS4066	NCS4086	NCS4106	NCS4115	NCS4196
					81	54	108	81	108	81	-	0
36"	18"	75"	3	2	NCS4007	NCS4027	NCS4047	NCS4067	NCS4087	NCS4107	NCS4116	NCS4197
		87"	4	4	NCS4008	NCS4028	NCS4048	NCS4068	NCS4088	NCS4108	NCS4117	NCS4198
					81	54	108	81	108	81	-	0

Drawer Height	Tray Height	Tray Width	Tray Depth	Weight
36"	3"	1	9	

- Choose a model with doors to prevent dust from settling on your tools.

















# SPIDER® SHELVING SYSTEM

Quick to assemble and built for heavy-duty industrial use, the Spider® Shelving System meets all of your storage needs. With multiple depth and height combinations to choose from, combined with a wide range of accessories, you can build a layout that will meet both your current and future needs. Assembly is easy: The shelves attach to the posts with four compression clips, so changing the layout is a quick and simple process.















Many configurations are possible, so contact Customer Service for a customized solution.

## OPEN SHELVING

									
		SR ...	SH ...	S ... E ...	S ... B ...	5-8	1 c/c		
									
36"	18"	75"	S_ _ 1002	S_ _ 1008	S_ _ 1014	S_ _ 1020	800lb		
	87"	S_ _ 1005	S_ _ 1011	S_ _ 1017	S_ _ 1023	800lb			
	24"	75"	S_ _ 1003	S_ _ 1009	S_ _ 1015	S_ _ 1021	625lb		
		87"	S_ _ 1006	S_ _ 1012	S_ _ 1018	S_ _ 1024	625lb		
48"	18"	75"	S_ _ 1032	S_ _ 1038	S_ _ 1044	S_ _ 1050	575lb		
		87"	S_ _ 1035	S_ _ 1041	S_ _ 1047	S_ _ 1053	575lb		
	24"	75"	S_ _ 1033	S_ _ 1039	S_ _ 1045	S_ _ 1051	600lb		
		87"	S_ _ 1036	S_ _ 1042	S_ _ 1048	S_ _ 1054	600lb		



## CLOSED SHELVING

									
		SR ...	SH ...	S ... E ...	S ... B ...	5-8	1 c/c		
									
36"	18"	75"	S_ _ 2002	S_ _ 2008	S_ _ 2014	S_ _ 2020	800lb		
		87"	S_ _ 2005	S_ _ 2011	S_ _ 2017	S_ _ 2023	800lb		
	24"	75"	S_ _ 2003	S_ _ 2009	S_ _ 2015	S_ _ 2021	625lb		
		87"	S_ _ 2006	S_ _ 2012	S_ _ 2018	S_ _ 2024	625lb		
48"	18"	75"	S_ _ 2032	S_ _ 2038	S_ _ 2044	S_ _ 2050	575lb		
		87"	S_ _ 2035	S_ _ 2041	S_ _ 2047	S_ _ 2053	575lb		
	24"	75"	S_ _ 2033	S_ _ 2039	S_ _ 2045	S_ _ 2051	600lb		
		87"	S_ _ 2036	S_ _ 2042	S_ _ 2048	S_ _ 2054	600lb		



# SPIDER® SHELVING SYSTEM

## SHELVING WITH DRAWERS

By choosing shelving with drawers, you can store both small and bulky items in the same unit, which means you are maximizing use of your available floor space.

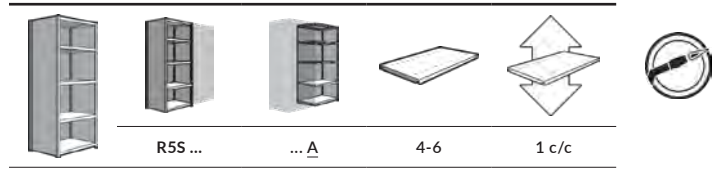

### SHELVING WITH 4 DRAWERS

Shelving Height	Shelving Depth	Drawer Depth	Number of Drawers	Product Code
36"	18"	75"	5	R5SEC-751801_
	18"	87"	6	R5SEC-871801_
36"	24"	75"	5	R5SEE-751801_
	24"	87"	6	R5SEE-871801_
48"	18"	75"	5	R5SHC-751801_
		87"	6	R5SHC-871801_
	24"	75"	5	R5SHE-751801_
		87"	6	R5SHE-871801_

Drawer Depth	Number of Compartments	Weight Capacity
4"	3	400lb
6"	1	

### SHELVING WITH 7 DRAWERS / ROLL-OUT SHELF

Shelving Height	Shelving Depth	Drawer Depth	Number of Drawers	Product Code
36"	18"	75"	4	R5SEC-754809_
	18"	87"	5	R5SEC-874809_
36"	24"	75"	4	R5SEE-754809_
	24"	87"	5	R5SEE-874809_
48"	18"	75"	4	R5SHC-754809_
		87"	5	R5SHC-874809_
	24"	75"	4	R5SHE-754809_
		87"	5	R5SHE-874809_

Drawer Depth	Number of Compartments	Weight Capacity
3"	2	400lb
4"	3	
6"	2	

Drawer Depth	Number of Compartments	Weight Capacity
6"	1	400lb

### SHELVING WITH 8 DRAWERS

Shelving Height	Shelving Depth	Drawer Depth	Number of Drawers	Product Code
36"	18"	75"	4	R5SEC-754801_
	18"	87"	5	R5SEC-874801_
36"	24"	75"	4	R5SEE-754801_
	24"	87"	5	R5SEE-874801_
48"	18"	75"	4	R5SHC-754801_
		87"	5	R5SHC-874801_
	24"	75"	4	R5SHE-754801_
		87"	5	R5SHE-874801_

Drawer Depth	Number of Compartments	Weight Capacity
6"	8	400lb

Shelving with drawers must be anchored to the floor.

## DRAWER PARTITIONING

Drawer Depth	36" Shelving Depth		18" Shelving Depth		36" Shelving Depth		24" Shelving Depth		48" Shelving Depth		18" Shelving Depth		48" Shelving Depth		24" Shelving Depth	
	Partitions	Units	Partitions	Units	Partitions	Units	Partitions	Units	Partitions	Units	Partitions	Units	Partitions	Units	Partitions	Units
3" - 5"	4	24	4	30	4	32	4	40								
6" - 8"	7.5	8	7	12	7.5	10	7	15								

NOTE: For drawers without compartments, replace the last two digits of the product number with the next even number up.

e.g.: R5SEC-751801 With  
R5SEC-751802 Without

# MINI-RACKING FOR CNC TOOLS

With a wide range of dimensions and options available, industrial-quality Rousseau Mini-Racking units offer an efficient way to store bulky items in a scalable system that easily adapts to specific needs. Easy to assemble and built to last, the Spider® Mini-Racking System is ideal for high-density storage of your CNC tools. For example, the option shown here provides quick access to your tools from both the front and rear.

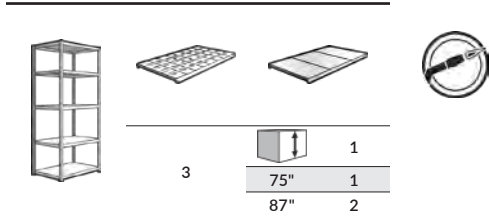

		TAPER 40	TAPER 50	HSK 50	HSK 63	50 KM	63 KM		
18"	75"	NCS6001	NCS6021	NCS6031	NCS6041	NCS6051	NCS6061	NCS6011	NCS6191
	87"	NCS6002	NCS6022	NCS6032	NCS6042	NCS6052	NCS6062	NCS6012	NCS6192
60"	MAX	210	120	240	150	240	150	-	0
	75"	NCS6003	NCS6023	NCS6033	NCS6043	NCS6053	NCS6063	NCS6013	NCS6193
24"	87"	NCS6004	NCS6024	NCS6034	NCS6044	NCS6054	NCS6064	NCS6014	NCS6194
	MAX	270	150	300	210	300	210	-	0
18"	75"	NCS6005	NCS6025	NCS6035	NCS6045	NCS6055	NCS6065	NCS6015	NCS6195
	87"	NCS6006	NCS6026	NCS6036	NCS6046	NCS6056	NCS6066	NCS6016	NCS6196
72"		250	144	288	180	288	180	-	0
	75"	NCS6007	NCS6027	NCS6037	NCS6047	NCS6057	NCS6067	NCS6017	NCS6197
24"	87"	NCS6008	NCS6028	NCS6038	NCS6048	NCS6058	NCS6068	NCS6018	NCS6198
	MAX	324	180	360	252	360	252	-	0



# STORAGE CABINETS, STATIONARY AND MOBILE

Rousseau's modular cabinets boast a heavy-duty and distinct design that is ideal for all environments. They are market-leading products thanks to the wide range of dimensions and accessories available, their modular design and, above all, their durability. The drawers have a load capacity of 400lb. each and can be opened to full extension. Each drawer comes subdivided.









**LIFETIME WARRANTY**  
The Rousseau drawer rolling mechanism is covered by a lifetime warranty.



## HIGH-DENSITY STORAGE CABINET

48" 24" 60" R5AHE-5809





	3"	1	400lb
	5"	1	
	6"	3	
	8"	2	
	12"	1	

- Designed for intensive use, the R Cabinet is perfect for storing tools and parts of all sizes.



## MOBILE REPAIR/PREPARATION CABINET FOR CNC TOOLS

36" 24" 61 1/2" 

Taper 40	14	NCM8121
Taper 50	10	NCM8131
HSK 50	20	NCM8141
HSK 63	14	NCM8151
50 KM	20	NCM8161
63 KM	14	NCM8171
	-	NCM8181
	0	NCM8191

30" 2



	4"	2	400lb
	6"	3	





6" 900lb

- Superior-quality casters for easier maneuverability
- Easy and safe transportation of CNC tools

## MULTI-DRAWER MOBILE CABINET

48" 24" 37 1/2" R5GHE-3025



	48"	4"	1	400lb
		3"	4	
	18"	4"	1	
		5"	1	
	30"	3"	4	
		9"	1	

6" 900lb

- Superior-quality casters for easier maneuverability

# WORKSTATION SYSTEM

## MULTI-PURPOSE WORKSTATION

Rousseau products are modular and versatile. For example, by combining shelving, a laminated wood top, utility panels, LED lighting and CNC tool racks, you have a complete workstation where everything is stored in the proper place. Each drawer comes subdivided.

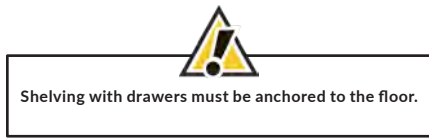
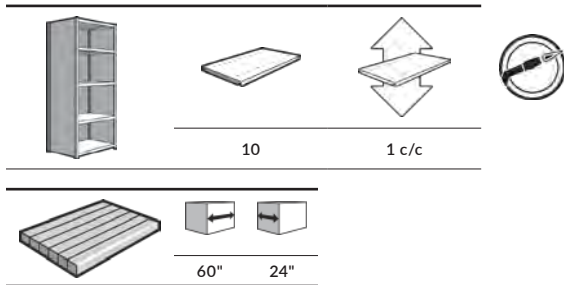

				TAPER 40	TAPER 50	HSK 50	HSK 63	50 KM	63 KM			
120"	24"	87"	8	NCS8004	NCS8013	NCS8023	NCS8033	NCS8043	NCS8053	NCS8074	NCS8094	
					91	65	130	91	130	91	-	0

30"	3"	1	4"	2	7"	2	9"	1	400lb	30"	13

				TAPER 40	TAPER 50	HSK 50	HSK 63	50 KM	63 KM			
132"	24"	87"	8	NCS8005	NCS8015	NCS8025	NCS8035	NCS8045	NCS8055	NCS8075	NCS8095	
					108	72	144	108	144	108	-	0

36"	3"	1	4"	2	7"	2	9"	1	400lb	36"	13

# WORKSTATION SYSTEM

We have the perfect customized solution whether you are looking for basic stationary or mobile workstations with or without storage space, or a more comprehensive workstation with multiple accessories.

You will love the versatility of our workstations and their ability to evolve along with your business needs by simply adding accessories, such as LED lights, riser shelves, power feed panels, 5S panels and

various holders. With multiple dimension combinations to choose from, you can create a completely customized space that meets the highest standards for ergonomics, safety and security.

And with CNC tool racks installed on WM uprights, you will always have your numerical control tools within easy reach.



## MAINTENANCE WORKSTATION WITH CNC TOOL RACKS

60"	30"	82"		
Taper 40	21	NCW0582		
Taper 50	15	NCW0584		
HSK 50	30	NCW0586		
HSK 63	21	NCW0588		
50 KM	30	NCW0590		
63 KM	21	NCW0592		
	-	NCW0096		
	0	NCW0598		

	30"	3
--	-----	---

	18"	21"	3"	2	100lb
		6"	3		

- Includes 1 LED light, 1 power outlet channel, 1 utility panel, 10 hooks and 2 tiltable shelves
- Ideal for sharpening, calibration and swapping out CNC tools

## TEMPORARY STORAGE WORKSTATION

60"	30"	58"		
Taper 40	14	NCW0622		
Taper 50	10	NCW0627		
HSK 50	20	NCW0632		
HSK 63	14	NCW0637		
50 KM	20	NCW0642		
63 KM	14	NCW0647		
	-	NCW0621		
	0	NCW0629		

	30"	2
--	-----	---

--

- Includes a painted steel shelf and stringer
- Ideal for daily tasks like CNC tool and parts handling and data processing

## MOBILE WORKBENCH

60"	30"	35 1/2"	
			WSW1031
	6"	900lb	

- For moving your workbench near to machining stations



# 5S STORAGE

Over the years, Rousseau has developed many different storage solutions to meet the standards of the 5S methodology. The aim of this Japanese technique is to continuously improve the work environment. It is designed to achieve better organization and an efficient work environment by ensuring each tool is in the right place, easy to find and well identified.

Furthermore, the storage solutions we offer help you to improve work conditions and morale for employees by reducing the time and energy they spend on unproductive tasks.



## WALL-MOUNTED PANEL SYSTEM

Rousseau's 5S multi-purpose panel system can be used to store a broad range of items of different sizes, shapes and weights on a single surface.

### Wall-Mounted Utility Panel

16"	18"	WM57-1618
	24"	WM57-1624
	36"	WM57-1636
	48"	WM57-1648
	72"	WM57-1672
24"	18"	WM57-2418
	24"	WM57-2424
	36"	WM57-2436
	48"	WM57-2448
	72"	WM57-2472

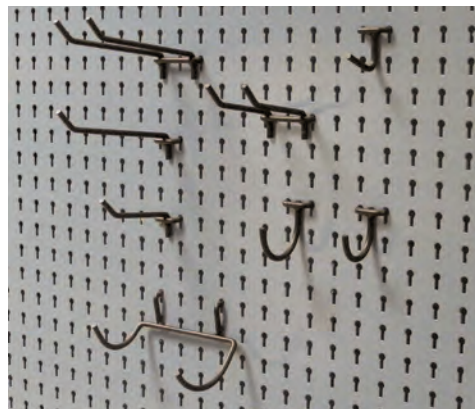

### Heavy-Duty Hooks

TYPE	DIMENSION	PRODUCT NO.	50 lb
Square	6"	WM9A-06	
	12"	WM9A-12	
Round	6"	WM9B-06	
	12"	WM9B-12	

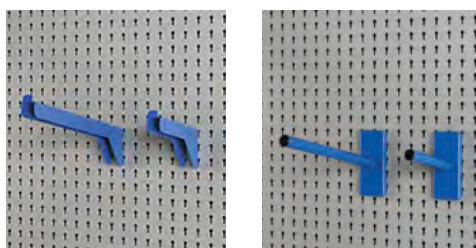

### Light-Duty Hooks

TYPE / PACKAGE	DIMENSION	PRODUCT NO.
Straight hooks / 20	1 1/2"D	WM9F-150
Single hooks / 20	1 1/2" dia.	WM9G-150
Single hooks / 20	2" dia.	WM9G-200
Double back single hooks / 10	3"D	WM9H-03
Double back single hooks / 10	5"D	WM9H-05
Double back double hooks / 10	3"D	WM9J-03
Double back double hooks / 10	5"D	WM9J-05
Drill holder / 1	5"W x 3 1/2"D	WM9L-01

## DRAWER ACCESSORIES

We offer a wide variety of drawer accessories that integrate with each other to help you organize and locate small parts.

TYPE	PRODUCT NO.
Front to Back Partition	RG00
Left to Right Partition	RG01
Drawer Dividers	RG10
Label Holder	RG51
Plastic Bins	RG20
Plastic Bin Partition / Divider	RG22 / RG24
Label Holder for Plastic Bins	RG52
Foam for Tools	RG42
Groove Trays	RG35
Handle Protector	RF70

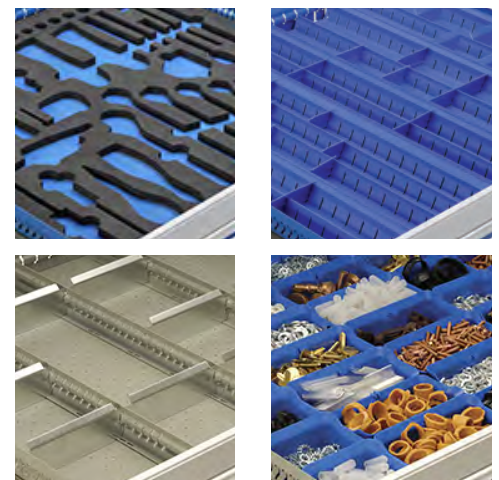



# MULTITEK CART

The MultiTek Cart provides an ergonomic way to transport and handle items and tools of different sizes. Lightweight and highly durable, it comes with a wide range of configurations and accessories to suit the unique needs of each work activity.

With a maximum load capacity of 600lb. and unrivaled versatility, it is the ideal companion to help you perform your daily tasks.



## MATERIAL HANDLING CART

36"	24"	42"	RV-VM4200K109
	2"	2	
	3"	2	
	5"		

- For moving parts and tools over long distances
- Sold non-assembled

## MAINTENANCE CART

31"	21"	37"	RV-NH37A2X104L3B
	3"	2	
	4"	2	
	3"		

- Sold assembled

## TECHNICIANS CART FOR FREQUENT TRIPS

25"	16"	37"	RV-GB37S2F106B
	3"	2	
	4"	2	
	3"		

- Sold assembled

## SHELF ACCESSORIES

Non-Slip PVC Liner for Shelf

Protective Foam for Shelf

Tool Foam for Shelf



## DRAWER ACCESSORIES

PVC Drawer Liner

Protective Foam for Drawer

Tool Foam for Drawer

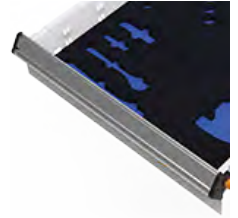



## ROUSSEAU METAL INC.

Since 1950 Rousseau has been designing, engineering and manufacturing modular and industrial storage systems for a variety of markets. Our facilities, covering 254,000 square feet in total and equipped with cutting-edge technology, are a sign of our growth and vitality.

We offer complete and integrated solutions for all your storage needs: drawers for shelving and cabinets, industrial shelving, Mini-Racking, workstations, hutches, carts, toolboxes, and much more.

Visit [www.rousseau.com](http://www.rousseau.com) for more information.

## COLORS

### STANDARD COLORS

The colors may differ slightly from those illustrated.

Avalanche Blue 055	Everest Blue 051	Classic Blue 052	Midnight Blue 057	Glossy Sapphire Blue 560	Glossy EverGreen 1025	Black 091	Beige 041
Frost White 061	Light Gray 071	Modern Gray 745	Charcoal Gray 072	Glossy Carbon Black 741	White 616	Sienna Orange 085	Glossy Yellow 208
Flame Red 081	Glossy Carmine Red 806	Glossy Cranberry Red 815	Glossy Black 902				

### HANDLE END CAPS

Ocean Blue 011	Black 031	Orange 021

For more information, please contact your local distributor:

## ROUSSEAU METAL INC.

105, AVENUE DE GASPÉ OUEST  
SAINT-JEAN-PORT-JOLI (QUÉBEC)  
G0R 3G0 CANADA

WEBSITE  
[rousseau.com](http://rousseau.com)

END USERS  
1.866.463.4270

EMAIL  
[info@rousseau.com](mailto:info@rousseau.com)

DISTRIBUTORS  
1.800.463.4271

DISTRIBUTORS ACCESS  
[e-rousseau.com](mailto:e-rousseau.com)

